

The 11th NEDO-CDTI Joint Workshop

“Technologies for Hydrogen Valley in Spain and Japan – Regional H2 Value Chain”

Hydrogen



High Pressure Compression system
for Hydrogen Society
Solution by ABC Compressors

Carlos Martín Andrés
CEO
ABC Compressors



Organization / Company

- ✓ Design, manufacturing and after sales service for reciprocating compressors for air and industrial gases for **80 years**.



+3.000 COMPRESORES **+ 300** WORKERS
+ 120 PAÍSES **+ 80** M €
+ 65 SAT



40%

20%



40%





Products, services, technologies of the company

- ✓ **30 years** manufacturing Hydrogen reciprocating compressors for the petrochemical industry

Scheme of operation

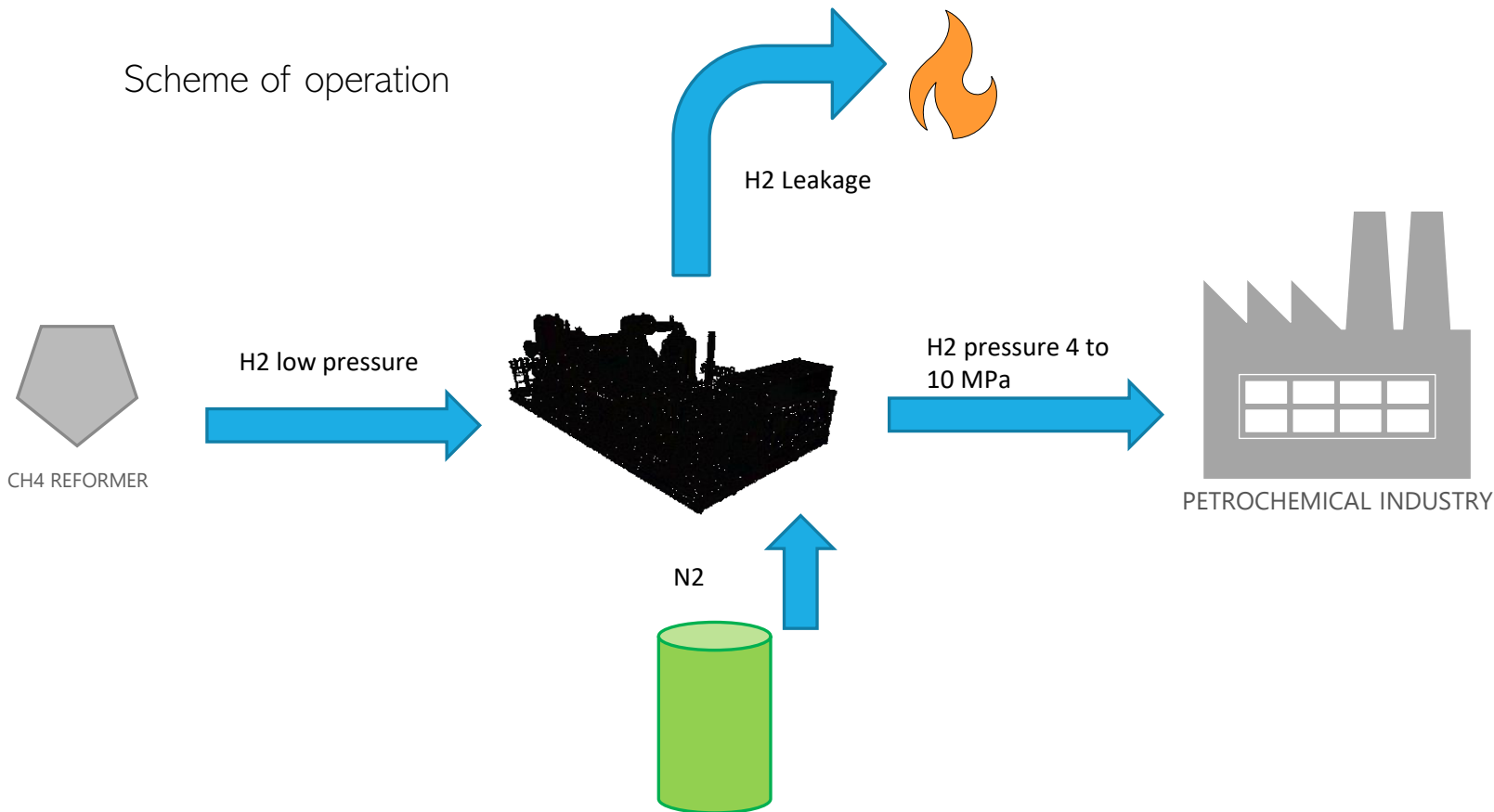



Main challenges and solutions in the project/case presented

✓ New scenario

■ Application

- Fuel cell (high purity)
- Mobility (high pressure)
- CH4 enrichment

✓ Renewable H2 origin

- Green Hydrogen is much more expensive than grey H2
- Leackages are no longer accepted, there will be no flare

✓ Challenges

- Adapt Recip to these requirement as Recips are the most efficient and reliable solution



Main challenges and solutions in the project/case presented

✓ First solution – Hermetic compressor

- Pressurized crackcase up to 3 MPa
- Magnetic coupling
- No N2 is required for operation

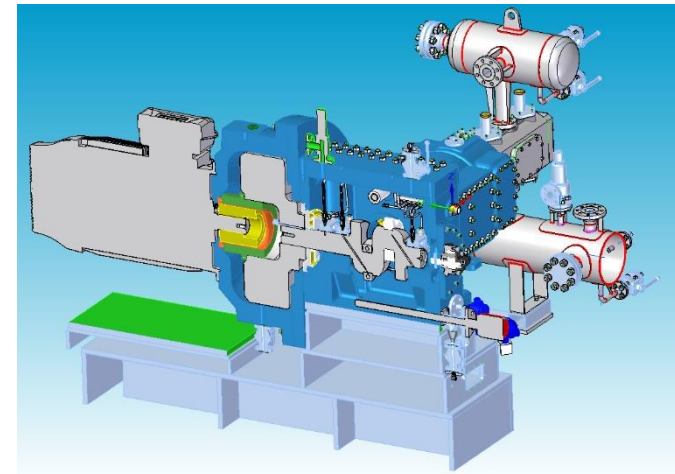
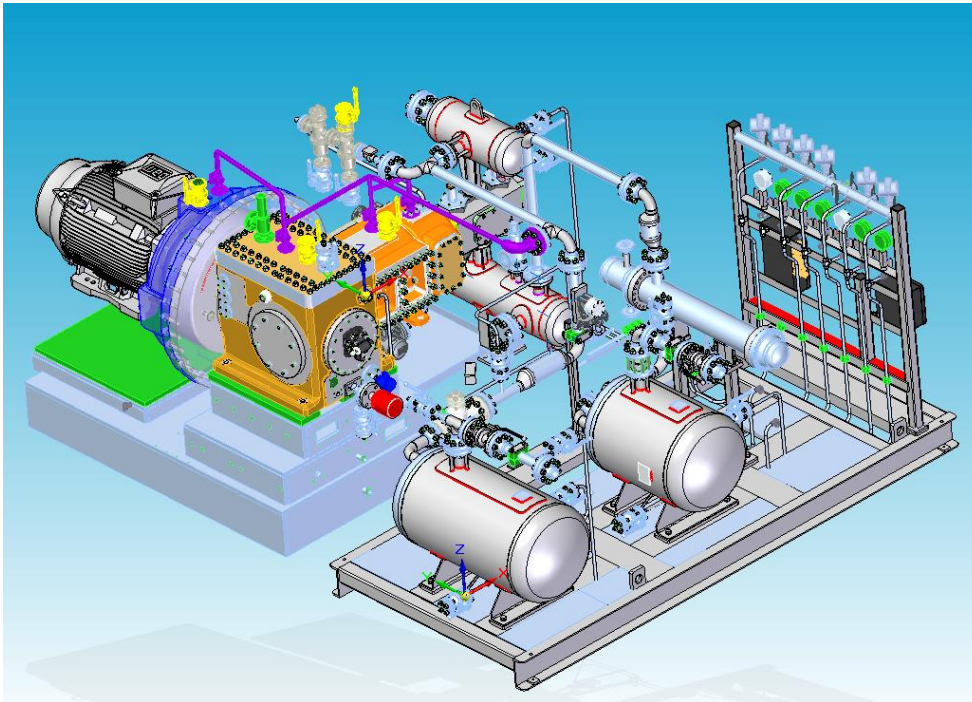
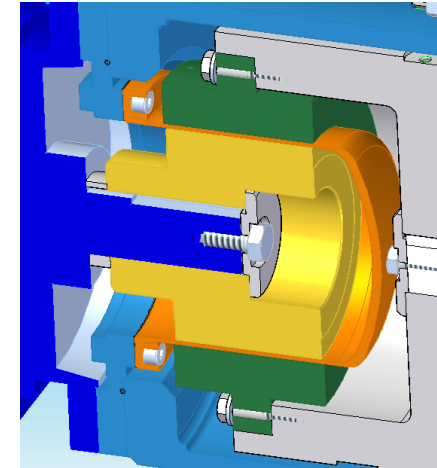



Main challenges and solutions in the project/case presented

✓ Second solution – Leakage recovery compressor

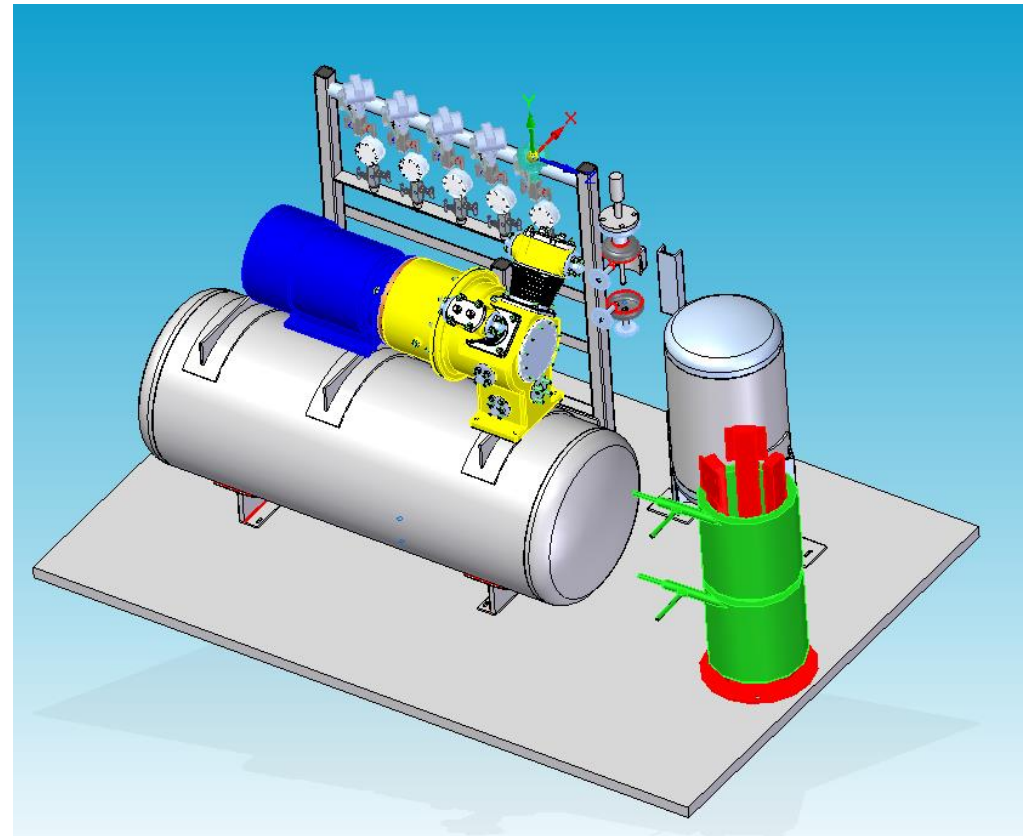
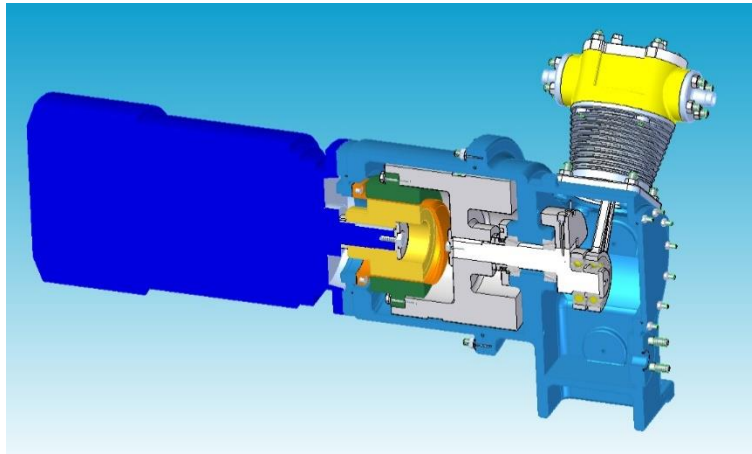



Main challenges and solutions in the project/case presented

✓ WASTE TO H2

Phase 1

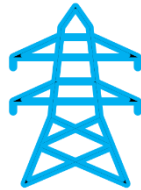



Main challenges and solutions in the project/case presented

✓ WASTE TO H2

Phase 2





Main challenges and solutions in the project/case presented

✓ WASTE TO H2

Phase 3



70%

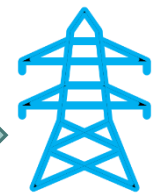

30%

Hydrogen generation and CO2 capture

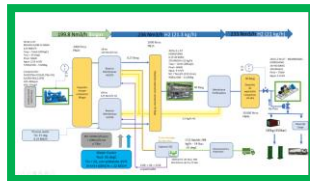



Main challenges and solutions in the project/case presented

✓ WASTE TO H2

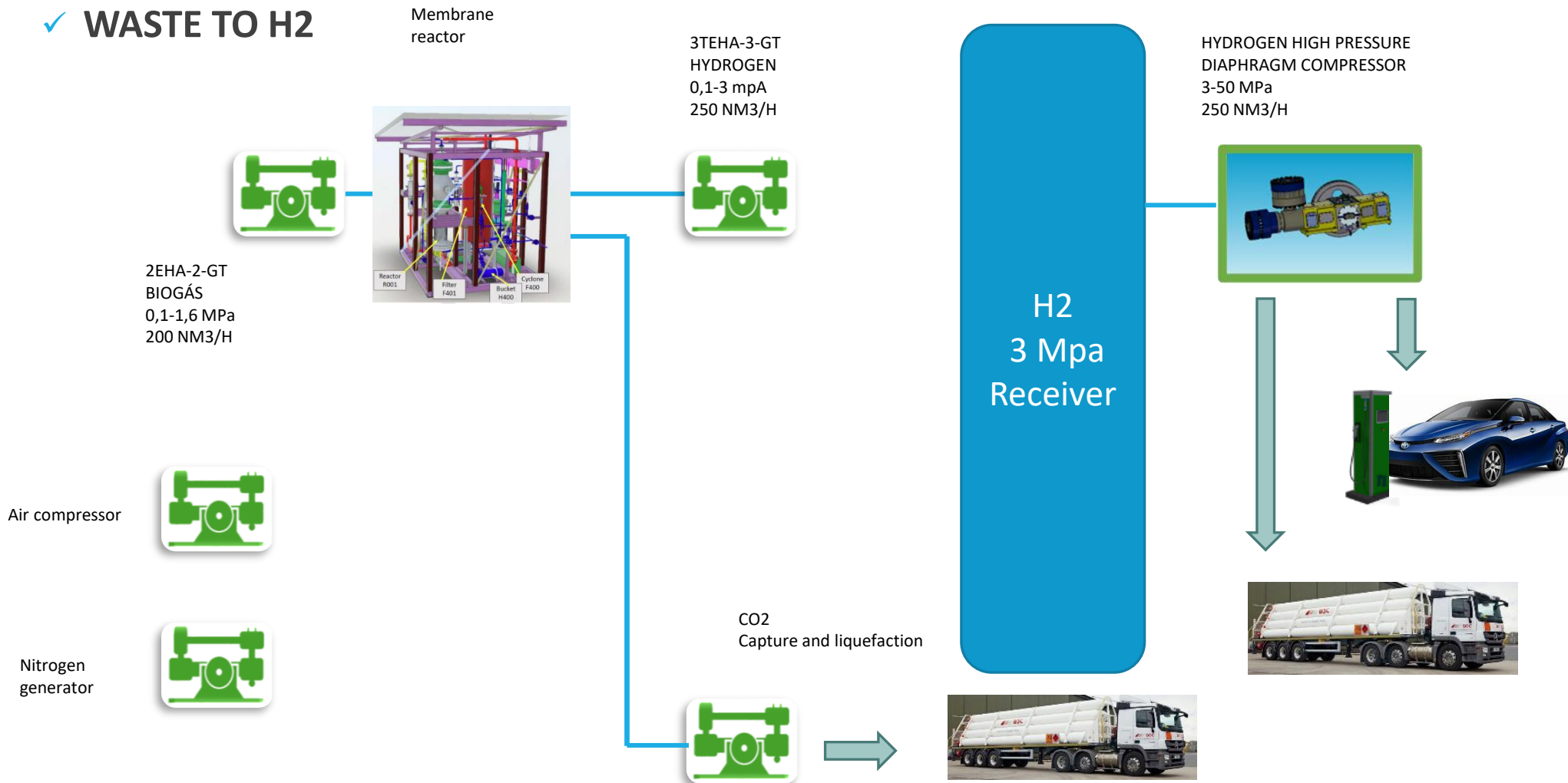

Hydrogen

水素が
次世代エネルギー
社会を切り拓く！



Ideas for a Japan – Spain collaboration

- ✓ Open to cooperate in Hydrogen projects
 - Engineering companies
 - Power generation
 - Suppliers



Contact Details

CARLOS MARTIN

CEO

ABC COMPRESSORS

AZITAIN 6 20600 EIBAR SPAIN

cmartin@abc-compressors.com

www.abc-compressors.com

+34 943 820400